

**Built to Deliver - Every Time**

## **ILV Vertical Lift** **4400 - 5500 LBS. CAPACITY**



**-OPTIMIZED-**  
**FLEXIBILITY**  
**DURABILITY**  
**PROFITABILITY**

**Reliability, weight and performance of a cantilever with unobstructed dock access. Functions with most door configurations.**

### **Heavy Duty Construction:**

- ◆ Bushings and zerks at all pivot points
- ◆ Wide Lift arm for stability and doubles applications
- ◆ Thermo protected power pack pre-installed, wired and filled with premium multi temp hydraulic fluid

### **Platform:**

- ◆ Flush mounted hinges for pallet and cart-friendly operation

### **Built in Safety Features:**

- ◆ Hydraulic locks on cylinder port
- ◆ Cab shut off switch
- ◆ 150 A Circuit Breaker

Our wide lift arm clears pintle hitches and allows installation on wide trailer frames with minor modifications. This lift works very well in double applications and it only protrudes approximately ten inches.

The sturdy 4 cylinder hydraulic system is standard with cylinder locks and is directly placed at the port of cylinder restricting pressure to the cylinder itself.



Lockable control boxes are pre-wired and tested. We offer three different control stations:

Side control, hand held remote, and optional foot controls in the liftgate platform.

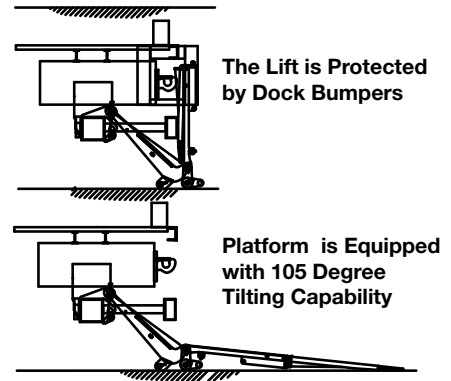
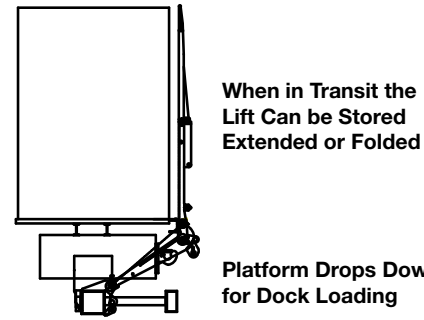

The added convenience of the automatic leveling option allows the platform to find the pre-set horizontal position on its own as well as tilt down at ground level only if the operator is still activating the controls. With this feature, the operator does not need to adjust the tilt angle manually.

Our ground roller eliminates wear on clevis and platform components when platform touches the ground maximizing your investment by reducing maintenance costs.

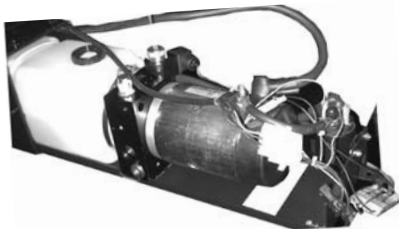

The pre-mounted power pack is fully enclosed in our mount tube for fast installation and slides out for easy inspection. This lockable mounting system keeps the power pack safely out of harms way. By using oversized and thermo-protected quality components we minimize our customers maintenance and down time.

**STANDARD FEATURES:**

- ◆ True Level Ride with ground tilt
- ◆ 150 A Circuit Breaker
- ◆ Cab Shut-Off Switch
- ◆ Hydraulic Cylinder Locks
- ◆ Low Maintenance Bushings
- ◆ Hand held remote

**LIFTGATE OPTIONS:**

- ◆ Carts stops
- ◆ Foot controls
- ◆ Swing door kit
- ◆ Aux. truck and trailer kit
- ◆ Custom made platforms
- ◆ Wireless Remote

Model	Lifting Capacity (Lbs.)	Platform Length* (Inches)	Platform Width (Inches)	Bed Height (Inches)	Approx. Weight (Lbs)	Mount Clearance (Inches)
ILV 44	4400	72	88	50 to 56	1150	30-36
ILV 55	5500	72	88	50 to 56	1210	30-36