

# **MBB** INTERLIFT

*Built to Deliver - Every Time*

## **ILUK Under Slider**

**3300, 4400, 5500 and 6600 LBS. CAPACITY**



**-OPTIMIZED-  
FLEXIBILITY  
DURABILITY  
PROFITABILITY**

### **LARGE LIFTGATE**

**Store out of the way!  
Use only when needed!**



#### **Concept:**

**The ILUK offers a large capacity level ride platform and is stored under the vehicle in a protected position ready for dock loading without any additional operations.**

#### **Controls and Power Pack:**

- ◆ Solid state control system for greater reliability
- ◆ Enclosed pre-mounted and pre-filled thermo protected power pack in the mount frame

#### **Heavy Duty Construction:**

- ◆ The four cylinder optimized construction provides a light unit with a low platform inclination

#### **Platform:**

- ◆ Heavy Duty platform with flush torsion assisted hinge
- ◆ ILUK 33 and 66, Steel/Aluminum
- ◆ ILUK 44-55, Aluminum/Aluminum
- ◆ Platform ground roller

**INTERLIFT, Inc.**

15939 Piuma Avenue  
Cerritos, CA 90703

**PALFINGER**  
North America Group

[www.interlift.net](http://www.interlift.net)

Tel (888) 774 5844 (562) 924 8218  
Fax (562) 924 8318

Considering the weight savings, the large platform sizes up to 82" x 96", and the storage position of the platform, the ILUK series is one of the most versatile liftgates in the market. This liftgate due to the capacity, true level ride, and platform size is ideal for sensitive loads as well as general distribution of large heavy cargo.

The design allows for maximum length on the vehicle and can be used with all flush door configurations.

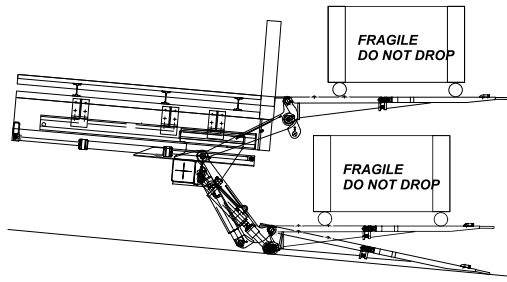

The adjustable platform and standard automatic leveling allows for the platform to find the pre-set horizontal position on its own. The operator can maintain level regardless of terrain and tilt down at ground level.

The power pack is fully enclosed in the mount tube for fast installation and slides out for easy inspection. This lockable system keeps the power pack safely out of harms way.



Lockable control box with automatic closing lid for protection houses the outside control. Additional hand and foot controls cover the operator's individual needs.

By using oversized thermo protected quality components we minimize our customers' maintenance and down time.

By the turn of a knob, the liftgate slides out from under the vehicle on low maintenance slide blocks. After unfolding the torsion assisted platform tip with minimal effort, the liftgate is ready for use.

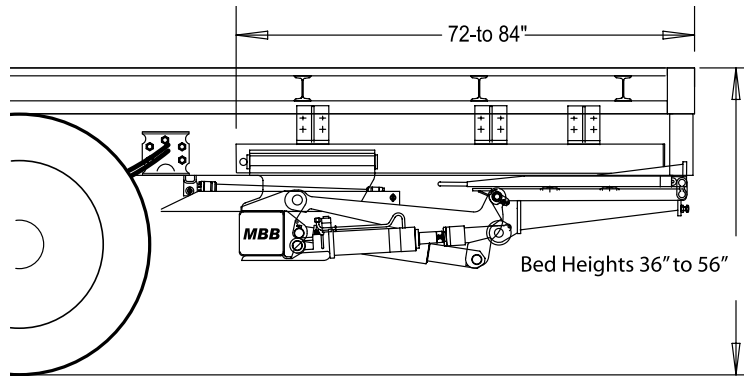

**STANDARD FEATURES:**

- ◆ True Level Ride with ground tilt
- ◆ Torsion assisted Tip
- ◆ Automatic Leveling
- ◆ On Off Switch
- ◆ Enclosed Power Pack
- ◆ Lockable Control Box
- ◆ Cart Stops are standard on ILUK 44, 55 and 66
- ◆ Foot controls standard on ILUK 44, 55 and 66
- ◆ Aluminum Platform is standard on ILUK 44 and 55
- ◆ ILUK 33 and 66 have a steel/aluminum platform
- ◆ Bushings and Zerks
- ◆ Hydraulic Cylinder Locks
- ◆ Four Cylinder Design
- ◆ Hand Remote
- ◆ Warning Lights
- ◆ Walk Ramp ready

**LIFTGATE OPTIONS:**

- ◆ Auxiliary Truck or Trailer Charge Kit
- ◆ Flat Floor Quick Mount Kit
- ◆ Low Floor Quick Mount Kit
- ◆ Truck Quick Mount Kit
- ◆ Removable Side Rails
- ◆ Wireless Remote

**ILUK 33 options only:**

- ◆ Aluminum Platform
- ◆ Cart Stops
- ◆ Foot Controls

Model	Lifting Capacity (Lbs.)	Platform Size Height (Inches)	Platform Width (Inches)	Bed Height* (inches)	Approx. Weight (Lbs)	Mount Clearance (inches)
ILUK 33	3300	72	96	36 to 56	1180	76
ILUK 44	4400	74 and 82	96	36 to 56	1250-1290	72-84
ILUK 55	5500	74 and 82	96	36 to 56	1350-1390	72-84
ILUK 66	6600	72 and 80	96	37 to 58	1600-1700	72-80

\*The minimum floor height dimensions are referring to frameless trailers.