

Built to Deliver - Every Time

ILR Route Pro **2000 - 2500 - 3000 LBS. CAPACITY**



-OPTIMIZED-
FLEXIBILITY
DURABILITY
PROFITABILITY

The ILR fits a wide range of trucks with floor heights from 36 to 53 inches. The two standard oversized platforms offer increased productivity at a budget price level.

Platform sizes up to a length of 48 inches (44" flat + 4" combo wedge with 10 degree incline) offers the best of two worlds with decreased platform angle, more space in front of cart stops and easy access on/off the platform.

Heavy Duty Construction:

- ◆ Bushings and zerks at all pivot points
- ◆ Oversized quality components
- ◆ Heat treated pins
- ◆ Thermo protected power pack pre-installed, wired and filled with premium multi temp hydraulic fluid

Minimum Laden Floor Height Requirement:

- Min. floor height on 42" platform=36"
- Min. floor height on 48" platform=38"

Platform:

- ◆ Combo wedge design 42" and 48" x 80"
- ◆ Dual torsion system for assisted folding on 48" platform
- ◆ Flush mounted hinges for pallet and cart-friendly operation

Built in Safety Features:

- ◆ Single cylinder with hydraulic lock on cylinder port
- ◆ Cab shut off switch
- ◆ 150 A Circuit Breaker

Interlift liftgates are built with oversized components for greater reliability. Our standard hydraulic cylinder lock provides more stability, better user control, and improved safety.



The pre-mounted, pre-filled with premium multi temp hydraulic fluid power pack is wired and fully enclosed in a H/D powder coated steel enclosure for fast installation, protection and easy inspection.



By using oversized and thermo protected quality components we minimize our customers maintenance and down time.



With the pre-wired and filled units with hydraulic fluid we can inspect and test the complete system prior to shipment.

The ILR's standard molded, marine type toggle switch can be placed in a variety of positions.

Mount frame Clearance:
Min. 26" - Max 36"

Bed Height Range:
36" laden - 53" unladen

(48" long platform - Min.
38" laden)

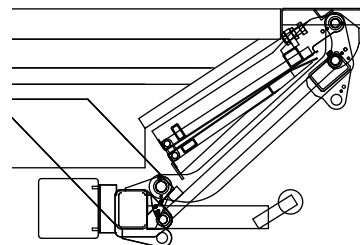

The one cylinder mid arm design provides great stability vs. assembly weight ratio. The platform rotates on an adjustable roller for different bed height installations.



The luxury of starting from a clean slate with modern 3-D CAD tools made it possible for us to develop an optimized one cylinder ramping ride unit with many features.

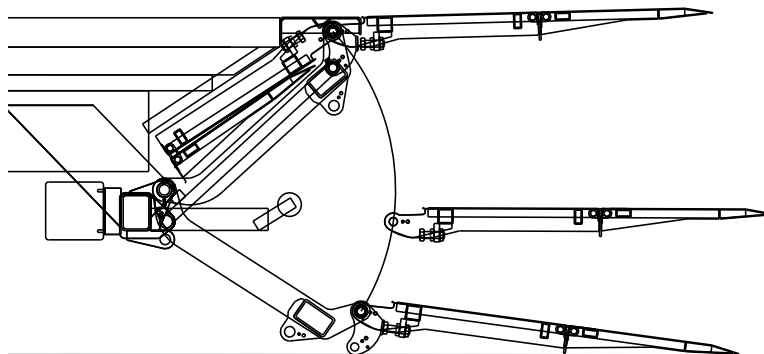

STANDARD FEATURES:

- ◆ 150 A Circuit Breaker
- ◆ Cab Shut-Off Switch
- ◆ Hydraulic Cylinder Lock
- ◆ Low Maintenance Bushings at all Pivot Points with Grease Zerks
- ◆ Dual Torsion Assisted Fold on 48" Platform
- ◆ Nylon roller for easy opening

LIFTGATE OPTIONS:

- ◆ 102" Bed Extensions
- ◆ Carts Stops
- ◆ Rubber Pads
- ◆ Mechanical Power Down Assist
- ◆ Hand held Remote
- ◆ H/D Dock Bumpers, Single or Dual Steps depending on Bed Heights
- ◆ Auxiliary Battery Kit
- ◆ Dual Controls
- ◆ Rear Impact guard
- ◆ 7000 lbs. Receiver tube
- ◆ Wireless Remote
- ◆ Remote Pump Kit (makes installations possible on some trucks with rear fuel tanks)

Model	Lifting Capacity (Lbs.)	Platform Length* (Inches)	Platform Width (Inches)	Bed Height (Inches)	Approx. Weight (Lbs)	Mount Clearance (Inches)
ILR 20	2000	42 & 48*	80	36 to 53	750	25 to 36
ILR 25	2500	42 & 48*	80	36 to 53	750	25 to 36
ILR 30	3000	42 & 48*	80	36 to 53	765	25 to 36

*The 48" length consists of 44" flat plus a 4" combo wedge with a 10 degree incline and requires a minimum of 38" laden bed height