

Built to Deliver - Every Time

ILF 4 "Auto-Fold"

3300, 4400 and 5500 LBS. CAPACITY

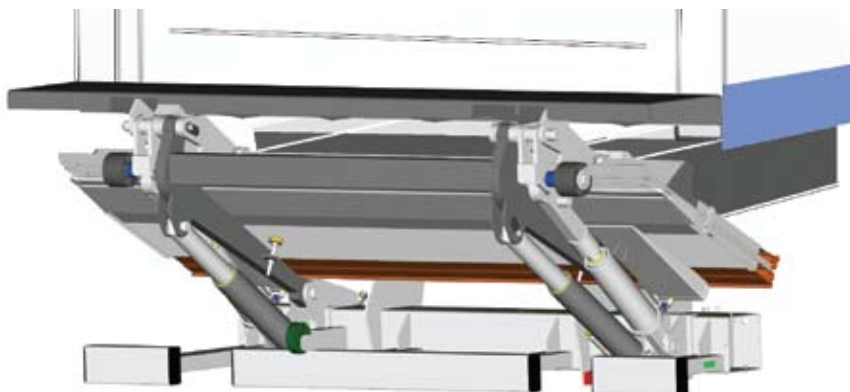

ILF 44-55



ILF 33

**-OPTIMIZED-
FLEXIBILITY
DURABILITY
PROFITABILITY**

With the turn of a button, the ILF practically self closes.

Our unique four cylinder folding lift allows for a level ride platform regardless of terrain. It compensates for up or down hill loading situations and offers one of the largest platforms in the class.

Easy Operation

- ◆ Adjustable roller and platform tip torsion assist
- ◆ Ease of operation provided by hydraulic assisted platform opening and closing

Built in Safety Features

- ◆ 4 cylinder stability and safety
- ◆ Cab shut off switch
- ◆ Hydraulic cylinder locks on cylinder ports

Large Level Ride Platform

- ◆ 63" x 86" all aluminum design for ILF 33
- ◆ 63" x 86" Steel - aluminum design for ILF 44-55
- ◆ Flush mounted hinges for pallet- and cart-friendly operation.

Thermo Protected Power Pack Inside Mount Frame:

- ◆ Decreases maintenance cost
- ◆ Increases life of components
- ◆ Delivered with multi-temp hydraulic fluid from factory

Wide Lift Arm

- ◆ Provides added stability
- ◆ Can accept a fixed hitch

Heavy-Duty Construction

- ◆ Bushings & zerks at all pivot points
- ◆ High quality components
- ◆ Heat treated pins
- ◆ Fixed 3 piece rear impact guard

- ◆ The INTERLIFT ILF series incorporates an unrivaled level of automation by design in its class. Most of the folding operation is done by turning a switch and letting the electro-hydraulics do the work. The operator is left to manually fold the torsion assisted tip section, which requires minimum effort of folding force, and to pull out and push in a near vertical platform when using the lift.
- ◆ INTERLIFT liftgates are built with over sized components for great reliability. Our standard hydraulic cylinder locks provide added stability, better user control, and improve operator safety.
- ◆ The 4 cylinder design can accommodate a fixed receiver hitch. The platform rotates on an adjustable roller to adapt for easier operation on different bed heights.



- ◆ The thermo protected power pack and the centrally located circuit board is fully enclosed in the mount tube for fast installations and slides out for easy inspection. By using oversized and thermo protected quality components we minimize our customers' maintenance and down time.

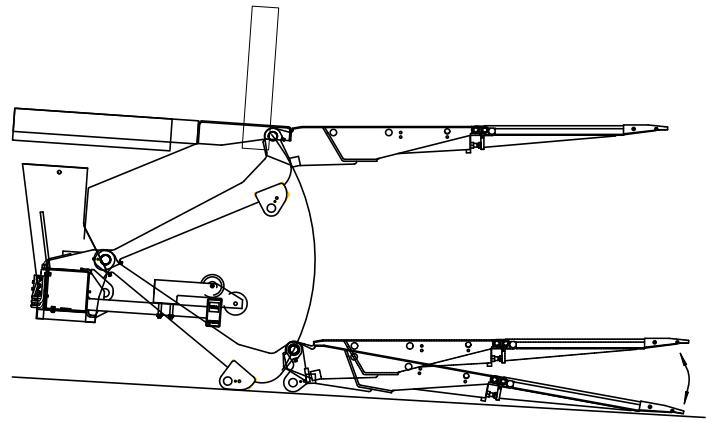
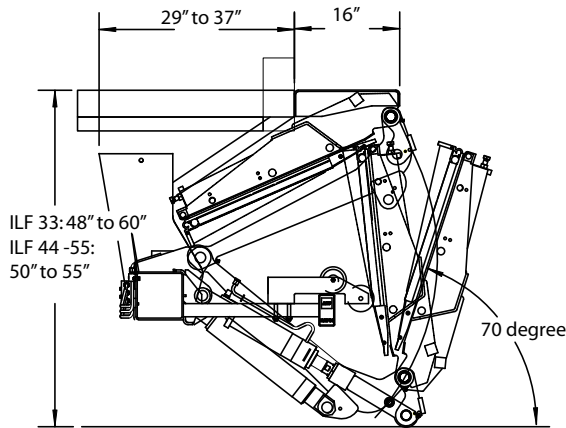

STANDARD FEATURES:

- ◆ True Level Ride
- ◆ Enclosed Power Pack
- ◆ Cab Shut-off Switch
- ◆ Hand Held Remote
- ◆ ILF 44-55 steel main section - aluminum tip
- ◆ ILF 33 aluminum platform
- ◆ Hydraulic Platform folding assist
- ◆ Torsion assisted aluminum tip section
- ◆ Bushings at All Pivot Point
- ◆ Hydraulic Cylinder Locks
- ◆ 3 Piece Rear Impact Guard

LIFTGATE OPTIONS:

- ◆ Auxiliary Truck and Trailer Kits
- ◆ Dock Bumpers
- ◆ Rubber Pads
- ◆ Carts Stops
- ◆ Extra Heavy Duty Trailer Dock Bumpers
- ◆ "DOT" Rear Impact Guard

Model	Lifting Capacity (Lbs.)	Platform Size Height (Inches)	Platform Width (Inches)	Bed Height (Inches)	Approx. Weight (Lbs)	Mount Clearance
ILF 33	3300	63	86	48" to 60"	1000	31" to 37"
ILF 44	4400	63	86	50" to 55"	1200	29" to 33"
ILF 55	5500	63	86	50" to 55"	1250	29" to 33"