

MBB INTERLIFT

Built to Deliver - Every Time

ILD Direct Lift

3500, 4400, 5500 and 6600 LBS. CAPACITY



**Direct Lift
with a Simplified
Electro Hydraulic Design**

**-OPTIMIZED-
FLEXIBILITY
DURABILITY
PROFITABILITY**

Automatic Self Leveling:

- ◆ Our hydraulic system eliminates the need of ever adjusting or replacing leveling /diverter valves

Enclosed Power Pack:

- ◆ Straight forward heavy duty electro-hydraulic system
- ◆ Dual pump and motor standard on 5500 and 6600 Lbs. capacity liftgates

Built in Safety Features:

- ◆ Automatic platform locks
- ◆ Controlled platform folding and unfolding
- ◆ Standard LED lights

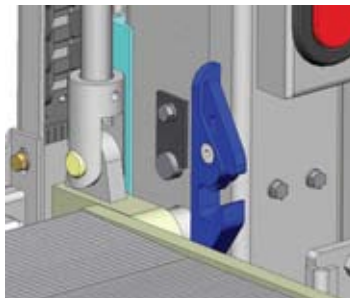

Heavy-Duty Construction:

- ◆ Bushings at major pivot points
- ◆ Low maintenance UHMW slide pads
- ◆ Standard, recessed bottom stops
- ◆ Flush entry threshold
- ◆ Sliding dock bumpers together with a massive column steel sleeve

INTERLIFT, Inc.

15939 Piuma Avenue
Cerritos, CA 90703

PALFINGER
North America Group

www.interlift.net

Tel (888) 774 5844 (562) 924 8218
Fax (562) 924 8318

The **ILD**, is available with platform sizes from 60", 72" and 84" deep for 96" and 102" wide applications. The platform can be equipped with a 12" fixed ramp with or without automatic cart stop or a 16" aluminum retention ramp.

INTERLIFT liftgates are built with oversized components for greater reliability. The large spread between the UHMW slide pads provide more stability and come with a lifetime warranty.

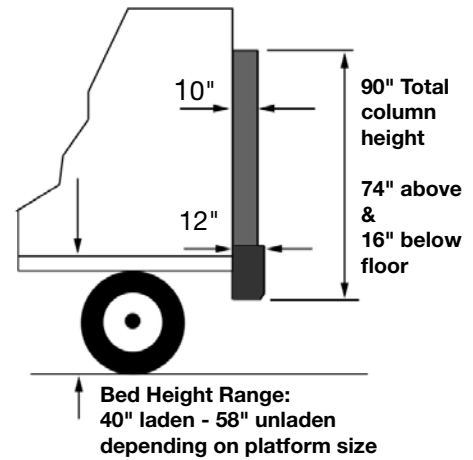

Control system The side mounted control station is a completely sealed unit.

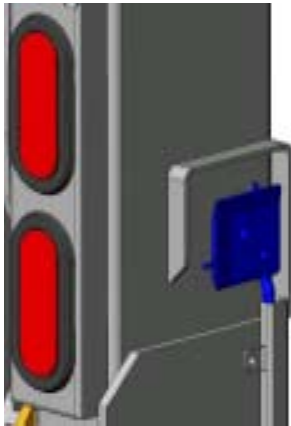

Hydraulic System A very simple self bleeding system that automatically levels the platform in its normal operation without any service or adjustments needed. The power open and close allows for a smooth folding of the platform. The hydraulic fittings are equipped with o-rings and have less than half as many connections than competing models.

Dual Pump & Motor

The 5500 and 6600 Lbs. capacity lifts are equipped with a dual pump & motor power pack. This can also be ordered as an option on the lesser capacity units.

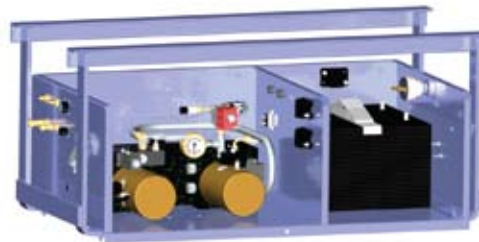

Power pack is fully enclosed in a steel box for protection and easy inspection. This keeps the power pack out of harms way. A built-in pressure gauge is provided for easy maintenance.

STANDARD FEATURES:

- ◆ LED Lights
- ◆ Enclosed Power Pack
- ◆ Adjustable Platform Chains
- ◆ Bushings and grease zerks @ Pivot Points
- ◆ Circuit Breaker
- ◆ Bottom Stops
- ◆ Master Disconnect Switch
- ◆ Power Down
- ◆ Replaceable Column Sleeves
- ◆ UHMW Sliding Dock Bumpers
- ◆ Built in Pressure gauge

LIFTGATE OPTIONS:

- ◆ Auxiliary Truck or Trailer Kits
- ◆ Cart Stops
- ◆ 16" aluminum Retention Ramp
- ◆ Hand Held Remote
- ◆ Dock Seal Kits
- ◆ 102" applications
- ◆ Aluminum Platforms
- ◆ Below Bed Storage
- ◆ Dual Pump and Motor (ILD 35 & ILD 44)

Model	Lifting Capacity (Lbs.)	Platform Size Height (Inches)	Platform Width (Inches)	Ramp Sizes and Style	Bed Height (inches)*	Approx. Weight (Lbs)*
ILD 35	3500	60 and 72	80, 86	12" fixed or 16" Alum. Retention	40 to 56	1780
ILD 44	4400	60, 72 and 84	80, 86		40 to 56	1865
ILD 55	5500	60, 72 and 84	80, 86		40 to 56	1920
ILD 66	6600	60, 72 and 84	80, 86		40 to 56	2077

*Depending on platform and ramp configuration